

ReachMaster introduces the **ReachMaster Basic DL72N** as the latest lift in its range of extreme compact aerial work platforms. The **ReachMaster Basic DL72N** represents an excellent combination between compact format, 72ft work height and value. It's compact width of only 2.9ft allows for access through single doors, and its light weight will allow for travel and set-up on virtually any surface. The multi-adjustable outrigger system will allow for set-up on uneven surfaces, and its standard all-wheel drive (3 wheel drive) will easily get it to its work area. A perfect solution for shopping malls, airports, entertainment facilities and churches with moderate reach requirements and limited access.

As with any ReachMaster product, safety is our number one concern and priority. The **ReachMaster Basic DL72N** is equipped with an automatic safety system that adjusts reach capacity according to basket load. Double safety devices on both electrical and hydraulic systems in combination with break hose valves and pressure control valve systems provide maximum protection for the operator. Proportional controls allows for smooth and pleasant aerial operation.

A wide range of options, including electric power, water or air to the basket, alternative power supply and battery options, allows you to tailor the lift to your specific application and needs.

Diagrams and Specs

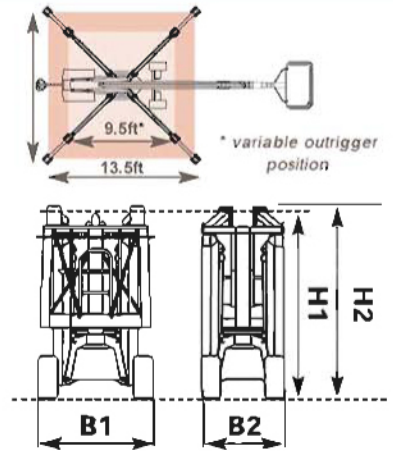
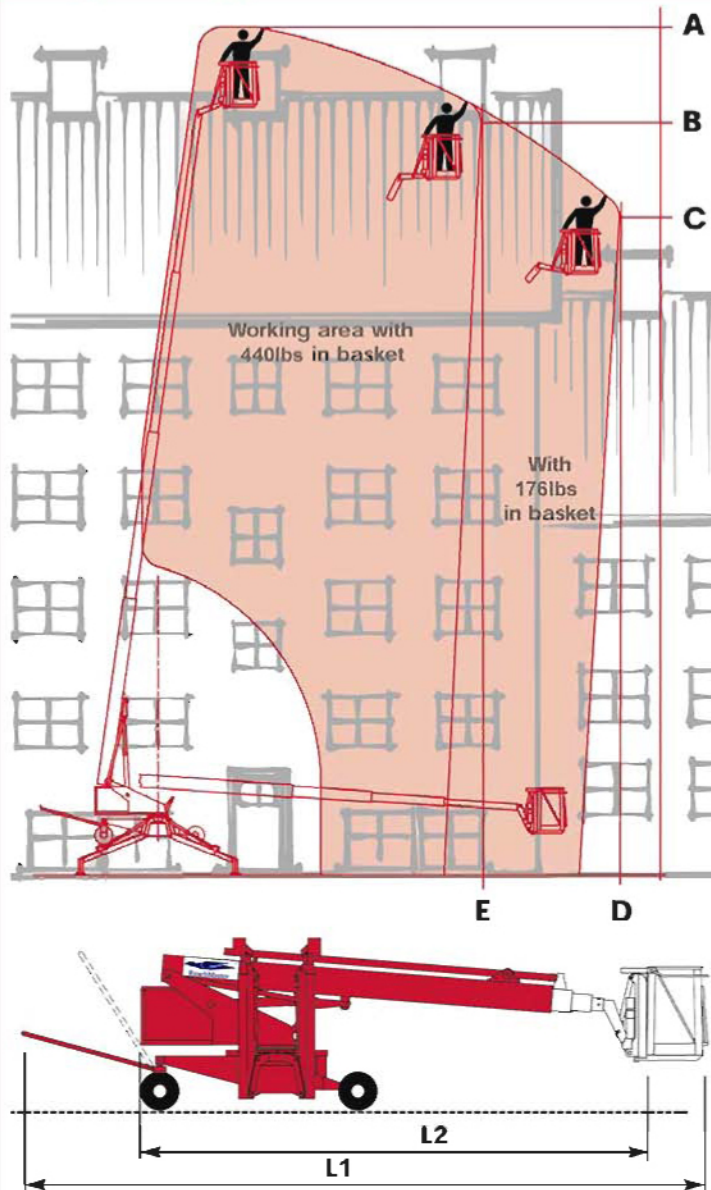

Specs:

Max Working Height A	72.0ft
Working Height B	64.0ft
Working Height C	57.4ft
Max Reach D	38.7ft
Reach E	27.2ft
Max load in basket	440lbs
Slew moment	Cont. 360°
Length L1	25.9ft
Length L2	21.4ft
Height H1	6.5ft
Height H2	7.0ft
Width B1	3.9ft
Width B2	2.9ft
Weight (standard)	5,060lbs
Speed, high	2.24mph
Speed, Low	0.78mph
Max climbing angle	12°/21%
Turning radius	8.5ft
Max pressure under wheel	41.5psi
Max pressure round foot plate	87.5psi
Max pressure wood foot plate	15.3psi

Standard and Optional Accessories

Standard Equipment:

- Rotating, detachable, alu. basket, 3.9ft
- Battery operation
- Proportional control
- Hydraulic outriggers
- Hydraulic wheel drive
- ELCB 30mA
- Hour counter
- Charging key
- Yellow rotating light

Optional Equipment:

- Variable outrigger position
- Current supply
- Outlets for air/water in the basket
- Height limiting system, 2 steps
- Diesel engine 5.0kW
- Special color
- Yellow, flashing light on the outriggers
- High capacity battery
- Bio degradable hydraulic oil
- Adjustable basket from ground level

The information and data in this brochure are not considered binding without express confirmation by ReachMaster, Inc and subject to change without notice