

Reach Diagram

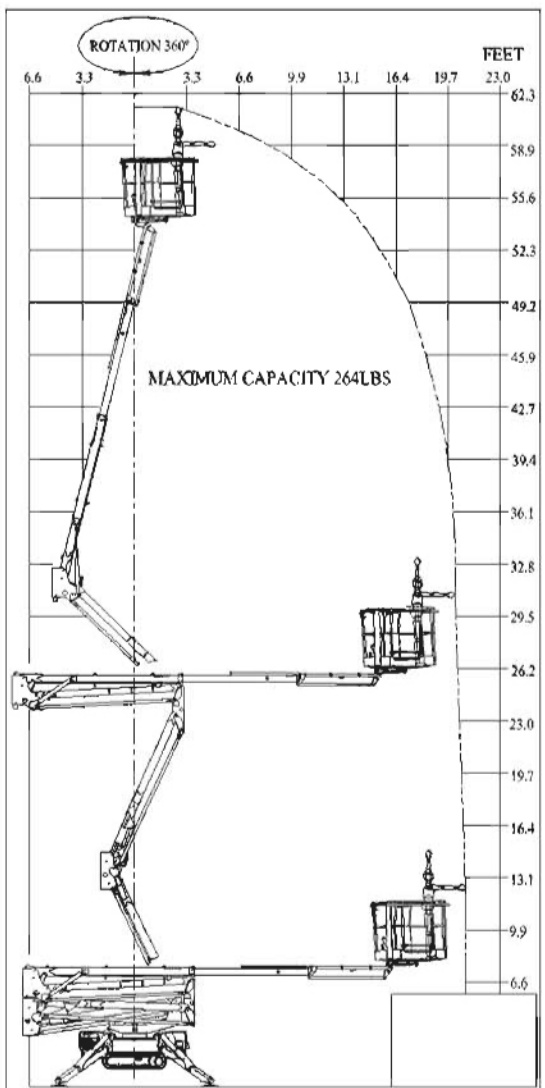
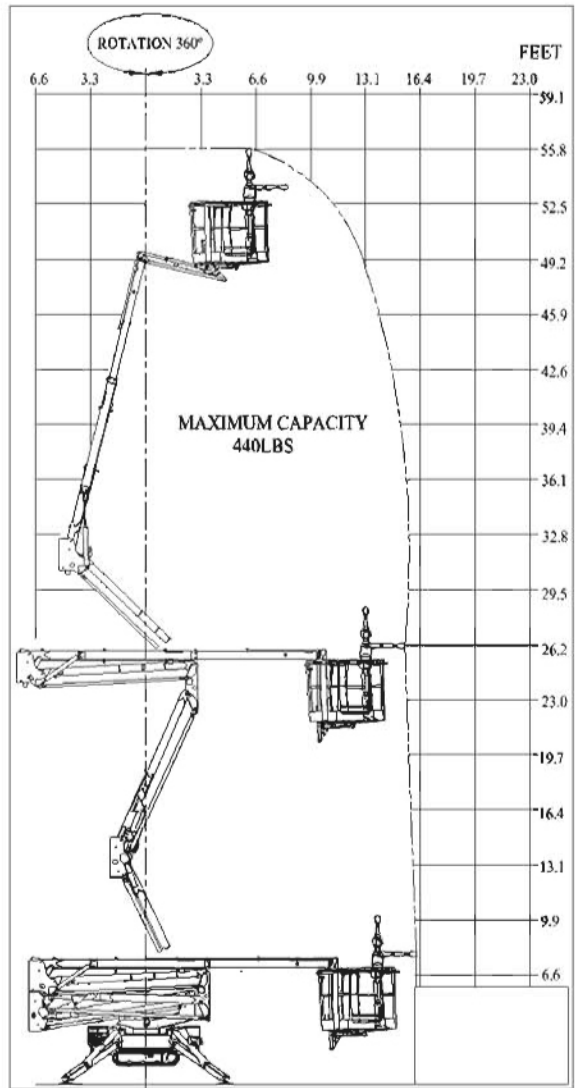

Quick Information

	<u>Basket Capacity 440lbs</u>	<u>Basket Capacity 264lbs</u>
Platform height	52.5ft	54.8ft
Working height	56.1ft	62.5ft
Max outreach	15.7ft	21.0ft
Length		14.7ft
Width (min)		2.6ft
Height		6.6ft
Weight		4,576lbs
Pressure under tracks		8.99psi
Pressure under outriggers		27.56psi

The information and data in this brochure are not considered binding without express confirmation by ReachMaster, Inc. and subject to change without notice

Reach Diagram

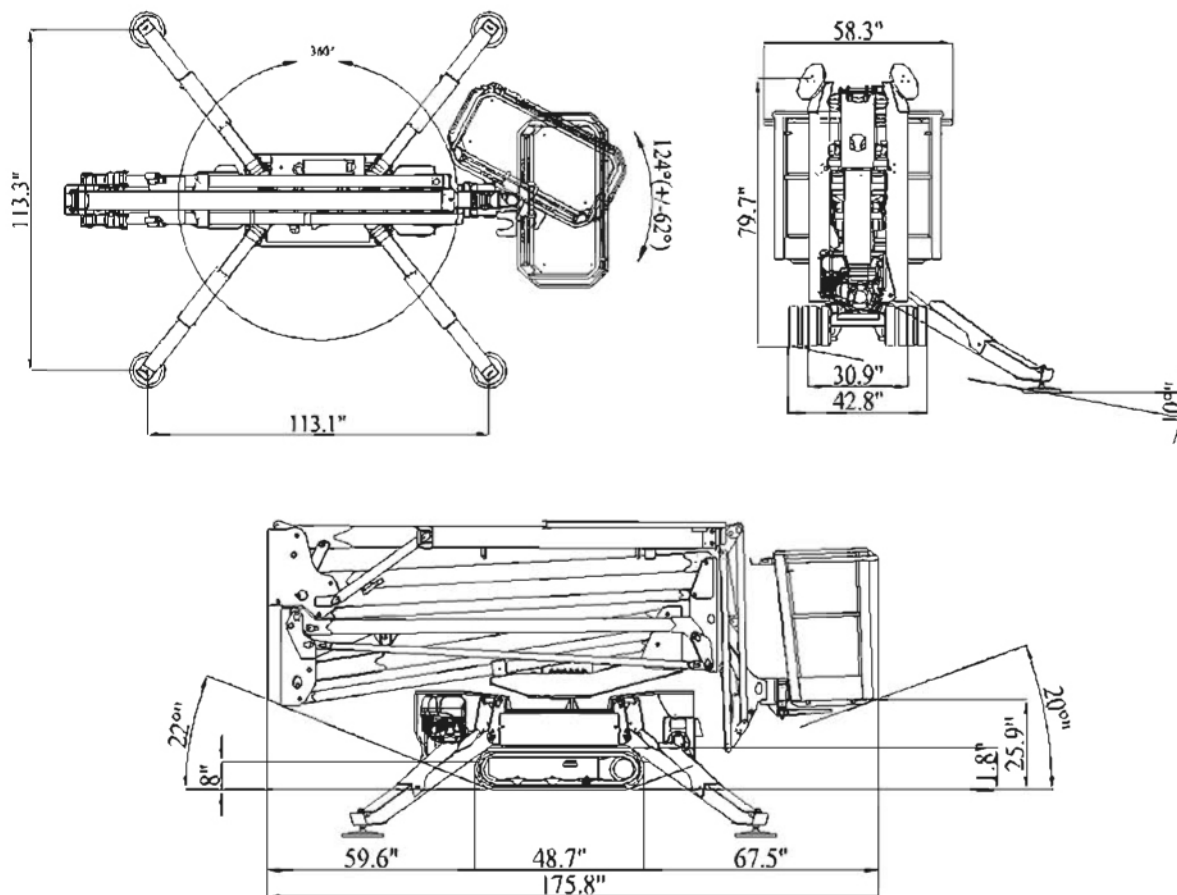

Technical Data

Standard Features:

Basket rotation	124° (2*62°)
Turret rotation (non cont.)	360°
Jib type articulated joint	82.7°
Max stabilization inclination	10°
Gasoline Engine (LL63)	Honda iGX440 – 15HP
Diesel Engine (LL63D)	Hatz 1B40—10HP
Electric motor	110V AC
Electric system voltage	12V
Max translation speed (standard)	0.87mph
Max translation speed (2 nd speed option)	0.87mph / 1.74mph
Max driving slope	20° / 36%
Max wind speed	27.96mph
Max manual force	89.9 pound-force

Other Standard Features:

Emergency lowering system, air to the basket, 110V to the basket, Start and Stop of main motor from the basket, removable remote control, load limiting device, double block valve on the stabilizers, stabilization warning lights, widening undercarriage.

The information and data in this brochure are not considered binding without express confirmation by ReachMaster, Inc. and subject to change without notice